



## Designation: D6193 – 16 (Reapproved 2020)

# Standard Practice for Stitches and Seams<sup>1</sup>

This standard is issued under the fixed designation D6193; the number immediately following the designation indicates the year of original adoption or, in the case of revision, the year of last revision. A number in parentheses indicates the year of last reapproval. A superscript epsilon ( $\epsilon$ ) indicates an editorial change since the last revision or reapproval.

*This standard has been approved for use by agencies of the U.S. Department of Defense.*

## 1. Scope

1.1 This practice covers the requirements and characteristics of stitches and seams used in the fabrication of sewn items.

1.2 This practice identifies the category, formation, and general purpose for stitch types and seam types used in the fabrication of sewn items.

1.3 Subsequent to a general discussion of stitches and seams that include schematic indices, this practice is comprised of the following sections that are listed in the order in which they appear:

1.3.1 *Section 5*—Classification of Stitch Types for which drawings are shown in [Stitch Figs. 1-69](#),

1.3.2 *Section 6*—Classification of Seam Types for which drawings are shown in [Seam Figs. 70-288](#), and

1.3.3 *Annex A1*—Seam Assembly Recommendations.

1.4 *This standard does not purport to address all of the safety concerns, if any, associated with its use. It is the responsibility of the user of this standard to establish appropriate safety, health, and environmental practices and determine the applicability of regulatory limitations prior to use.*

1.5 *This international standard was developed in accordance with internationally recognized principles on standardization established in the Decision on Principles for the Development of International Standards, Guides and Recommendations issued by the World Trade Organization Technical Barriers to Trade (TBT) Committee.*

## 2. Referenced Documents

2.1 *ASTM Standards:*<sup>2</sup>

[D123 Terminology Relating to Textiles](#)

## 3. Terminology

3.1 *Definitions:*

<sup>1</sup> This practice is under the jurisdiction of ASTM Committee [D13](#) on Textiles and is the direct responsibility of Subcommittee [D13.54](#) on Subassemblies.

Current edition approved July 1, 2020. Published August 2020. Originally approved in 1997. Last previous edition approved in 2016 as D6193 – 16. DOI: 10.1520/D6193-16R20.

<sup>2</sup> For referenced ASTM standards, visit the ASTM website, [www.astm.org](http://www.astm.org), or contact ASTM Customer Service at [service@astm.org](mailto:service@astm.org). For *Annual Book of ASTM Standards* volume information, refer to the standard's Document Summary page on the ASTM website.

3.1.1 *bartack, n*—a reinforcement stitch that effectively minimizes tearing at the ends of critical stress stitchlines.

3.1.1.1 *Discussion*—Examples of critical stress stitchlines include: ends of seams, zippers, pocket flaps, crotch/seat seams, collars, webbing and other components. If the bartacking process exhibits an insufficient number of stitches, improper thread size relationship or shortened bartack stitched length then it will fail under stress. Bartacking, because of the stitch density, can exhibit severe needle-cutting, thus creating a self-destructive characteristic if number of stitches is excessive, or sewing needle or thread size is too large for fabric. Bartacking is specified strictly as a relationship between length, width or throw and total stitches. It does not incorporate stitches per inch as a typical seam may specify.

3.1.1.2 *Discussion*—Counting finished bartack stitches is virtually impossible since the overall process consists of three components. The process begins in a horizontal position to achieve the required length and then forms the familiar zig-zag stitch-line along the horizontal plane including backstitching at both ends to lock in the zig-zag stitches to prevent raveling. The zig-zag stitches criss-cross the initial horizontal stitch line thus virtually hiding the initial stitch line.

3.1.2 *needle damage, n*—in sewn fabrics, the partial or complete yarn severance or fiber fusing caused by a needle passing through a fabric during sewing.

3.1.2.1 *Discussion*—This can also be referred to as needle cuts.

3.1.3 *seam, n*—a line where two or more fabrics are joined, usually near the edge. *See also sewn seam, glued seam, stapled seam, thermally bonded seam.*)

3.1.4 *seam allowance, n*—in sewn fabrics, the distance from the edge of a fabric to the parallel stitch line furthest from that edge.

3.1.5 *seam assembly, n*—the composite structure obtained when fabric(s) are joined by means of a seam.

3.1.6 *seam damage, n*— in sewn fabrics, an adverse change in the physical condition of one or more of the components in a seam which would reduce the seam acceptability such as yarn slippage, needle damage, or fabric rupture.

3.1.7 *seam efficiency, n*—in sewn fabrics, the ratio of seam strength to fabric strength.

**TABLE 1 Stitch and Seam Defects**

<i>Stitch Defects</i>	<i>Seam Assembly Defects</i>
Loose stitches	Puckers
Poorly formed stitches	Twists
Crowded stitches	Plaits
Tight stitches	Undulations
Crooked stitches	Run-off (raised seams)
Skipped stitches	Raw edges exposed (felled seams)

3.1.7.1 *Discussion*—For some constructions, yarn strength and stitch type can contribute to a higher seam efficiency value.

3.1.8 *seam slippage, n—in sewn fabrics*, the displacement of the fabric yarn parallel and adjacent to the stitch line.

3.1.9 *seam type, n—in sewn fabrics*, an alphanumeric designation relating to the essential characteristics of fabric positioning and rows of stitching in a specified sewn fabric seam.

3.1.10 *sew, v—to unite or fasten with stitches.*

3.1.11 *sewing thread, n—a flexible, small-diameter yarn or strand, usually treated with a surface coating, lubricant, or both, intended to be used to stitch one or more pieces of material or an object to a material.*

3.1.12 *sewn seam, n—in sewn fabrics*, a juncture at which two or more planar structures such as textile fabrics, are joined by sewing, usually near the edge.

3.1.13 *stitch, n—in sewing*, the configuration of the interlacing of sewing thread in a specific repeated unit. (See also *stitching, and stitch type.*)

3.1.14 *stitch density, n—in sewn seams*, the number of stitches per unit length in one row of stitching in the seam.

3.1.14.1 *Discussion*—This is usually expressed as stitches per inch (spi).

3.1.15 *stitch gage, n—in sewn seams*, the perpendicular distance between adjacent parallel rows of stitching.

3.1.16 *stitch type, n—in sewn seams*, a numerical designation relating to the essential characteristics of the interlacing of sewing thread(s) in a specified stitch.

3.1.17 *stitching, n—a series of stitches embodied in a material or materials of planar structure such as woven textile fabrics usually for ornamental purposes or finishing an edge, or both.*

3.1.18 *yarn slippage, n—in sewn seams in sewn fabrics*, the displacement of one or more yarns from the original position, causing differences in alignment, spacing, or both.

3.2 For definitions of other textile terms used in this practice, refer to Terminology [D123](#).

## 4. Significance and Use

4.1 Seam engineering, the determination of the best stitch type, seam configuration, and thread type which should be used for a particular assembly, requires a thorough knowledge of many variables. The improper selection of any one component can result in failure of the sewn junction, and ultimately failure of the product manufactured.

4.2 *General Characteristics*—The characteristics of a properly constructed sewn seam are strength, elasticity, durability, security, and appearance. These characteristics must be balanced with the properties of the material to be joined to form the optimum sewn seam. The end use of the item will govern the relative importance of these characteristics. The selection of the seam type and stitch type should be based upon these considerations.

4.2.1 *Strength*—The seam efficiency of the sewn seam should be as high as possible. This will produce sewn seam strength with a balanced construction that will withstand the forces encountered in the use of the sewn item. The elements affecting the strength of a sewn seam are:

- 4.2.1.1 Fabric type and strength,
- 4.2.1.2 Seam type,
- 4.2.1.3 Stitch type,
- 4.2.1.4 Stitch density (spi),
- 4.2.1.5 Thread tension, and
- 4.2.1.6 Thread strength.

4.2.2 *Elasticity*—The elasticity of a sewn seam should be slightly greater than that of the material which it joins. This will enable the material to support its share of the forces encountered for the intended end use of the sewn item. The elasticity of a sewn seam depends upon:

- 4.2.2.1 Fabric type and strength,
- 4.2.2.2 Seam type,
- 4.2.2.3 Stitch type,
- 4.2.2.4 Stitch density (spi),
- 4.2.2.5 Thread tension, and
- 4.2.2.6 Thread elasticity.

4.2.3 *Durability*—The durability of a sewn seam depends largely upon its strength relative to the elasticity of the seam and the elasticity of the material. However, in less elastic, tightly woven or dense materials, there is a tendency for the plies to “work” or slide on each other. To form a durable sewn seam in these types of fabrics, the thread size must be carefully chosen. The stitch density also needs to be carefully determined for the material so as not to cause excess tension which will unbalance the elasticity and cause puckering. It is also important to minimize abrasion and wear by contact with outside agencies to promote durability.

4.2.4 *Security*—The security of a sewn seam depends chiefly upon the stitch type, spi, and its susceptibility to become unraveled. The stitch must be well set to the material to prevent snagging that can cause rupture of the thread and unraveling of certain stitch types.

4.2.5 *Appearance*—The appearance of a sewn seam generally is governed by the proper relationship between the size and type of thread, the stitch density, and the texture and weight of the fabric.

4.2.5.1 In addition to these general characteristics, the technique and skill of the sewing machine operators also govern the appearance of the sewn seams. Some of the factors which will adversely affect the appearance are shown in [Table 1](#).

## 5. Classification of Stitch Types

5.1 *Function*—Because all stitch types require that a needle penetrate a fabric while transporting a sewing thread, it is

DIRECTION OF SUCCESSIVE STITCH FORMATION

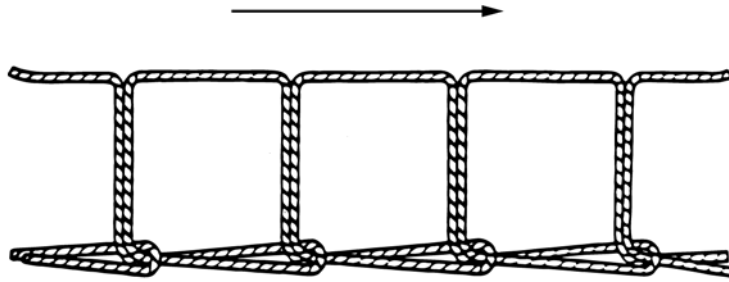

NOTE 1—This type of stitch shall be formed with one needle thread that shall be passed through the material and interlooped with itself on the undersurface of the material.

FIG. 1 Stitch Type 101

DIRECTION OF SUCCESSIVE STITCH FORMATION

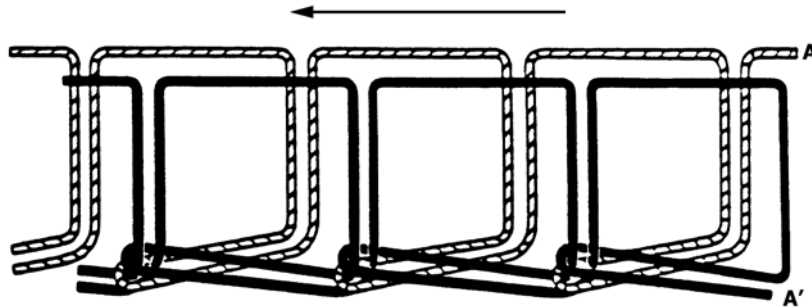

NOTE 1—This type of stitch shall be formed with two needle threads A and A'. Both threads shall be passed through the material and thread A' shall be interlooped with itself and with thread A.

FIG. 2 Stitch Type 102

DIRECTION OF SUCCESSIVE STITCH FORMATION

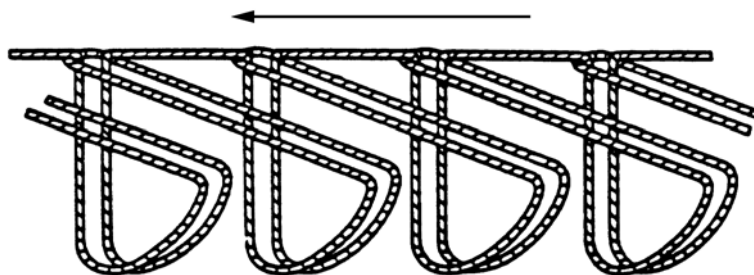

NOTE 1—This type of stitch shall be formed with one needle thread, which shall interloop with itself on the top surface of the material. The thread shall be passed through the top ply and horizontally through portions of the bottom ply without penetrating it the full depth.

FIG. 3 Stitch Type 103

DIRECTION OF SUCCESSIVE STITCH FORMATION

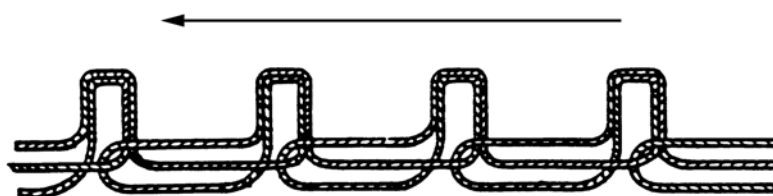

NOTE 1—This type of stitch shall be formed with one needle thread which shall interloop with itself on the undersurface of the material.

FIG. 4 Stitch Type 104

important to understand how the unique characteristics of every stitch type are dependent upon the mechanical actions of the sewing machine. See Stitch Type [Figs. 1-66](#).

## 5.2 Stitch Requirements:

5.2.1 Stitches are divided into six classes which are identified by the first digit of three digit numerals. Each class is